

# SERIES AZ 1000

## SINGLE STAGE REGULATOR

Flow Rates to 120 slpm



- SS 316L construction
- 10  $\mu$ m. surface finish (25  $\mu$ m. optional)
- Vacuum to 3500 psig (241 bar) inlet
- 1 to 300 psig (0.07 to 21 bar) outlet
- Cleaned, assembled and packaged for high purity semiconductor applications
- Flow rates
  - Standard to 30 slpm
  - HF option to 120 slpm
- Regulator of choice for point of use applications
- Knob LOTO (refer to AP KL data sheet)
- Installation and operating instructions available at [www.aptech-online.com](http://www.aptech-online.com) in the Tech Briefs section

### Operating Parameters

Source pressure		vacuum to 3,500 psig (241 bar)
	AZ 1001 and TF option	vacuum to 300 psig (21 bar)
Delivery pressure	AZ 1001	1 to 10 psig (0.07 to 0.7 bar)
	AZ 1002	1 to 30 psig (0.07 to 2 bar)
	AZ 1006	2 to 60 psig (0.14 to 4 bar)
	AZ 1010	2 to 100 psig (0.14 to 7 bar)
	AZ 1015	5 to 150 psig (.34 to 10 bar)
	AZ 1030	5 to 300 psig (.34 to 21 bar)
Proof pressure		150% of operating pressures
Burst pressure		300% of operating pressures

### Other Parameters

Inlet/outlet connectors		1/4 or 3/8 inch face seal or tube weld
Flow coefficient (Cv)		0.09 (0.15 HF option)
Internal volume		0.49 in <sup>3</sup> (8 cm <sup>3</sup> )
Operating temperature		-40° to +160°F (-40° to +71°C)*
Surface finish		10 $\mu$ m. (0.25 $\mu$ m) Ra avg. standard 25 $\mu$ m. (0.62 $\mu$ m) Ra avg. optional
Inboard leakage		2 x 10 <sup>-10</sup> sccs
Outboard leakage		2 x 10 <sup>-9</sup> sccs He
Leakage across seat		4 x 10 <sup>-8</sup> sccs He
Installation		surface or panel (optional)
Supply pressure effect		0.25 psig per 100 psig source pressure change
	HF	0.75 psig per 100 psig source pressure change

\*VS option 14° to 194°F (-10° to + 90°C).

### Materials

	Series AZ 1000 S	Series AZ 1000 SHP
Wetted Parts		
Body, nozzle	SS 316L**	SS 316L**
Poppet, diaphragm	SS 316L	Ni-Cr-Mo alloy / UNS N06022
Finish	electropolished and passivated	electropolished and passivated
Seat	PCTFE (Polyimide and PTFE optional)	PCTFE (PTFE optional)

All specifications subject to change without notice.

\*\*Please refer to product note PN 414 regarding single melt 316L SS material

# ULTRACLEAN BY DESIGN AND MANUFACTURING

## DIMENSIONAL INFORMATION

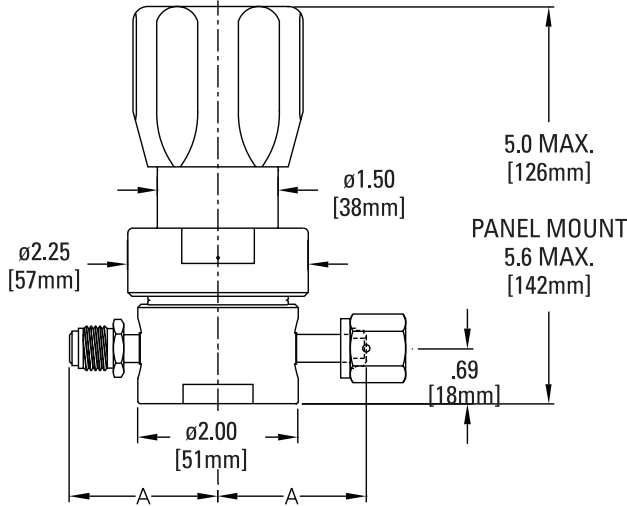

All dimensions in inches. Metric dimensions (mm) are for reference only.

Face Seal	A	
	in	mm
1/4"	1.85 ±.01	47
3/8"	2.35 ±.02	60

## PORTING CONFIGURATIONS

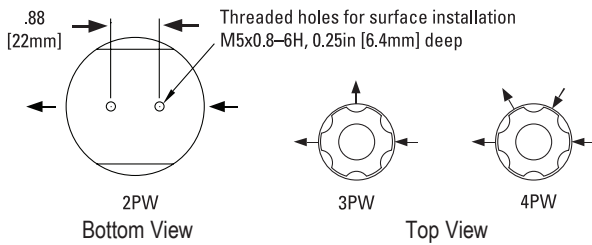

**CAUTION:** Product selection is the sole responsibility of the user, regardless of any recommendations or suggestions made by the factory. The user shall make selections based upon their own analysis and testing with regard to function, material compatibility and product ratings. Proper installation, operation and maintenance are also required to assure safe, trouble free performance.

## ORDERING INFORMATION

Sample Order Number

**AZ 1010SQ 2PW FV4 FV4**

**AZ 1010 | Series**

AZ 1001 = 1-10 psig (.07 to .7 bar)  
 AZ 1002 = 1-30 psig (.07 to 2 bar)  
 AZ 1006 = 2-60 psig (.14 to 4 bar)  
 AZ 1010 = 2-100 psig (.14 to 7 bar)  
 AZ 1015 = 5-150 psig (.34 to 10 bar)  
 AZ 1030 = 5-300 psig (.34 to 21 bar)

**S | Material**

S = Stainless steel (SS)  
 SHP = SS/Ni-Cr-Mo alloy poppet and diaphragm

**Q | Surface Finish Option**

Q = 25 µin. Ra avg.

**2PW | Ports**

2PW = 2 ports butt weld  
 3PW = 3 ports butt weld  
 4PW = 4 ports butt weld

**FV4 FV4 | Connections Inlet / Outlet**

FV4 = 1/4 inch face seal female  
 MV4 = 1/4 inch face seal male  
 FV6 = 3/8 inch face seal female  
 MV6 = 3/8 inch face seal male

Tube weld stub available

**Delivery Gauge\***

0 = No gauge  
 V3 = 30-0-30 psig/bar  
 L = 30-0-60 psig/bar  
 1 = 0-100 psig/bar  
 H = 30-0-160 psig/bar  
 4 = 0-400 psig/bar  
 10 = 0-1000 psig/bar  
 40 = 0-4000 psig/bar

\* Standard gauge port is 1/4 inch face seal male (1/4 inch face seal female are available).

**Options**

VS = Polyimide seat  
 TF = PTFE seat  
 HF = High flow  
 P = Panel installation\*\*  
 KL = Knob LOTO (refer to AP KL data sheet)

\*\* Panel hole 1.56" diameter.

AP Tech has product options and variations which are not documented in data sheets. If you have a model number that is not defined by the ordering information, please consult the factory or your local representative.

