



SERIES SL 5500

SPRINGLESS REGULATOR

Low Flow — High Pressure

- Single stage
- Hot DI cleaned and baked
- 10 μ m surface finish (7 and 5 μ m opt)
- Absolute to 100 psig delivery
- Vacuum to 3,500 psig (241 bar) inlet
- Low internal volume and surface area
- Flow rates to 30 slpm
- Cylinder and point of use applications
- Installation and operating instructions available at www.aptech-online.com in the Tech Briefs section

Operating Parameters

Source pressure	vacuum to 3,500 psig (241 bar)
Delivery pressure	SL 5502 1 to 30 psig (0.07 to 2 bar)
	SL 5502A 100 mm Hg absolute to 30 psig (100 torr to 2 bar)
	SL 5506 1 to 60 psig (0.07 to 4 bar)
	SL 5510 2 to 100 psig (0.14 to 7 bar)
Proof pressure	5,000 psig (345 bar)
Burst pressure	10,000 psig (690 bar)

Other Parameters

Inlet /outlet connectors	1/4 or 3/8 inch face seal or tube weld
Bonnet port	1/8 inch NPT
Flow coefficient (Cv)	0.09
Internal volume	0.55 in ³ (9 cm ³)
Operating temperature	-40° to +160°F (-40° to +71°C)
Surface finish	10 μ m (0.25 μ m) Ra max standard; 7 μ m (0.18 μ m); and 5 μ m (0.13 μ m) optional
Inboard leakage	2 x 10 ⁻¹⁰ sccs
Outboard leakage	2 x 10 ⁻⁹ sccs He at 1,500 psig inlet pressure
Leakage across seat	4 x 10 ⁻⁸ sccs He at 1,000 psig inlet pressure
Installation	surface or panel (optional)
Supply pressure effect	0.25 psig per 100 psig source pressure change

Materials

Type of Service	Series SL 5500 S Noncorrosive	Series SL 5500 SH Corrosive
Wetted Parts		
Body	SS 316L secondary remelt	SS 316L secondary remelt
Poppet, diaphragm	SS 316L	Ni-Cr-Mo alloy / UNS N06022
Finish	electropolished and passivated	electropolished and passivated
Seat	PCTFE (Polyimide optional)	PCTFE

All specifications subject to change without notice.

UNCOMPROMISING QUALITY, PERFORMANCE AND RELIABILITY

DIMENSIONAL INFORMATION

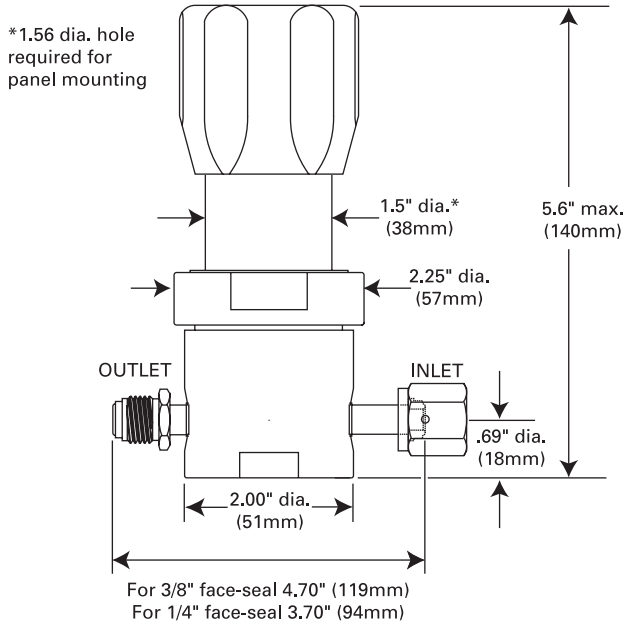

All dimensions in inches (mm). Metric dimensions are for reference only.

PORTING CONFIGURATIONS

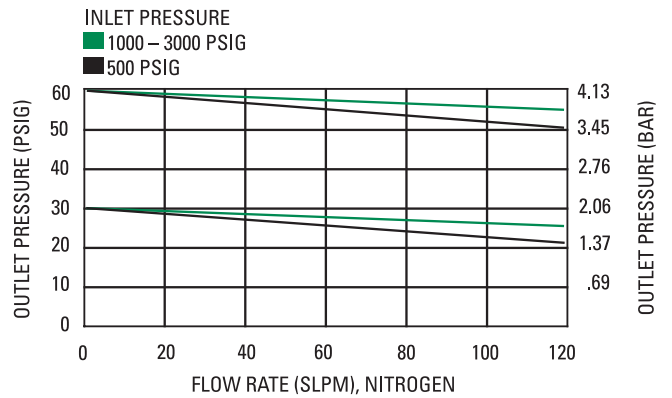
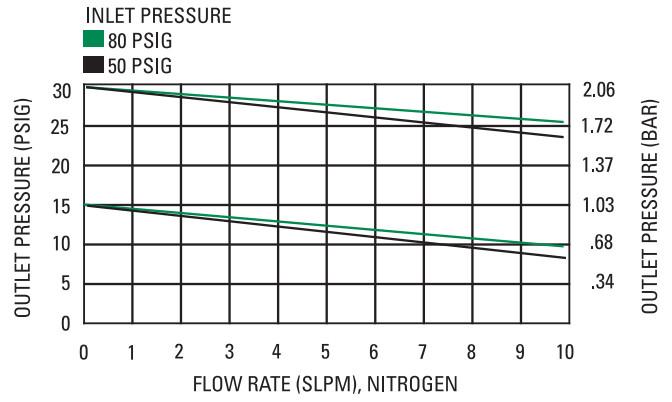
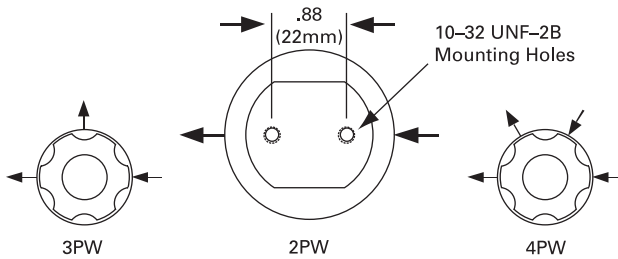

CAUTION: Product selection is the sole responsibility of the user, regardless of any recommendations or suggestions made by the factory. The user shall make selections based upon their own analysis and testing with regard to function, material compatibility and product ratings. Proper installation, operation and maintenance are also required to assure safe, trouble free performance.

ORDERING INFORMATION

Sample Order Number

SL 5510SM 4PW FV4 FV4 40 1 P

SL 5510 Series	SL 5502 = 1-30 psig (.07-2 bar) SL 5506 = 1-60 psig (.07-4 bar) SL 5510 = 2-100 psig (.14-7 bar)
S Material	S = Stainless steel (SS) SH = SS with Ni-Cr-Mo alloy internals
M Surface Finish Options	M = 10 μin. Ra max (standard) V = 7 μin. Ra max X = 5 μin. Ra max
Range Option	A = 100mm Hg absolute to 30 psig (2 bar) (SL 5502 only)
4PW Ports	2PW = 2 ports butt weld 3PW = 3 ports butt weld 4PW = 4 ports butt weld

FV4 FV4 | Connections Inlet / Outlet

FV4 = 1/4 inch face seal female
MV4 = 1/4 inch face seal male
FV6 = 3/8 inch face seal female
MV6 = 3/8 inch face seal male

Tube weld available

40 1 | Gauges* Source / Delivery

0 = No gauge
V3 = 30-0-30 psig/bar
L = 30-0-60 psig/bar
1 = 30-0-100 psig/bar
2 = 0-200 psig/bar
4 = 0-400 psig/bar
10 = 0-1000 psig/bar
40 = 0-4000 psig/bar

* Standard gauge ports are 1/4 inch face seal male

P | Options

P = Panel installation**
VS = Polyimide seat

** On panel mount option, bonnet port is not threaded. Panel hole 1.56" diameter.

AP Tech has product options and variations which are not documented in data sheets. If you have a model number that is not defined by the ordering information, please consult the factory or your local representative.